

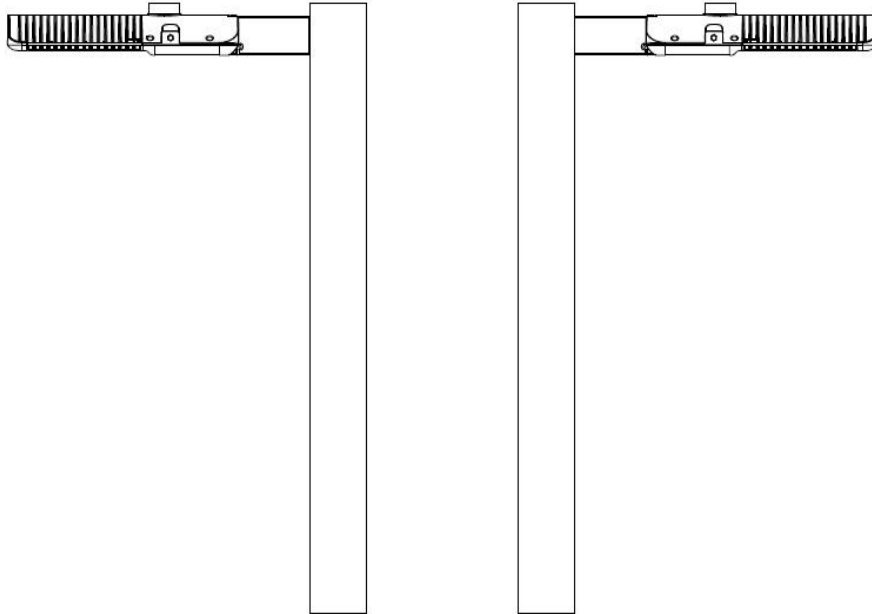

## Installation Instruction for AOK iT LED Parking Lot Light



Please read the installation manual carefully before installation and keep the manual for future use.



### Warning

1. Electrician must have related certificates, knowledge and working experience. The work must be assigned to each electrician based on their position and responsibility.

2. The lens of parking lot light modules are PC material, they may be scratched by any careless handling. The parking lot light must be carefully protected in installation, especially when the face of luminaire is put downward, it needs to be protected with soft cloth or other protecting materials.

3. Installation must be proceeded when the electricity is shut off, no action be taken when there is electricity connected.

4. Construction must be proceeded according to related regulations, including the tools and equipments used. For example: working voltage range, Warning sign, flashing lamp, helmet, and working clothes etc.

5. Make sure the weather is suitable for high power electricity work when proceed construction.



## Statement

1. Installation of parking lot light must be proceeded with cranes with lifting platform, warning sign and flash lamp etc.
2. Installation and maintenance of Parking Lot Light must be proceeded when the electricity is off.
3. Maintenance must be proceeded with professional staff.

## Preparation for installation of LED parking lot light

**Step 1:** Open the package, remove the packing materials and take out the LED Lamp

**Step 2:** Take away the screws and stamping gasket from the Square mounting bracket as below picture

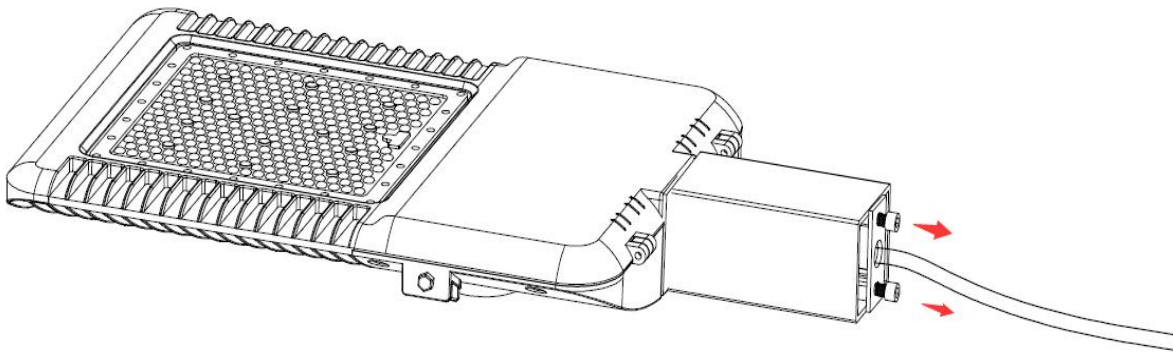

## Step 3

Drill holes on the square pole according to the hole position on the mounting bracket, make the driver cable on the lamp go through the holes to the pole, fix the taken out screws from inside of the pole to the bracket, using inner hexagonal screw driver to fasten the screws. As below picture shown.

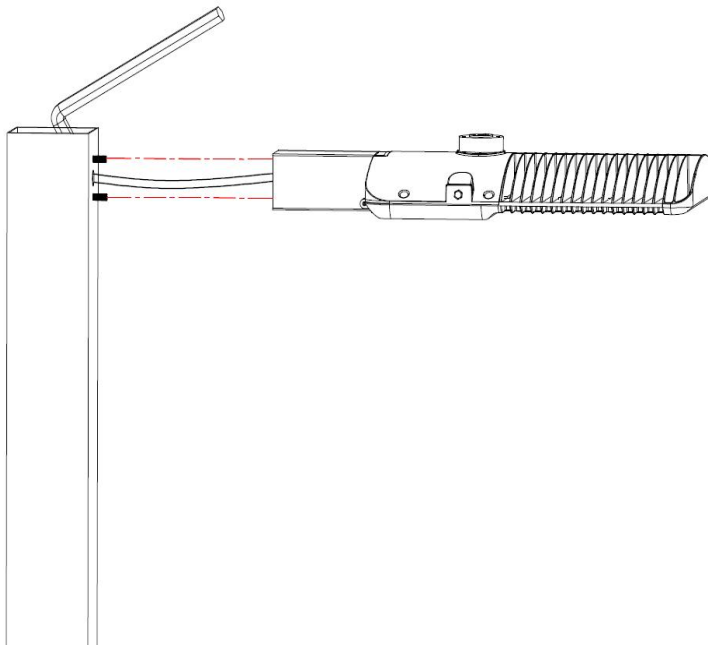

#### Step 4

Wiring, connect the L,N,GND wires on the lamp to the L,N,GND cables on the poles accordingly

(Remark: US stanadr Black: L, White: N, Green: GND; Eur Standard: Brown:L, Blue:N, Yellow Green: GND)

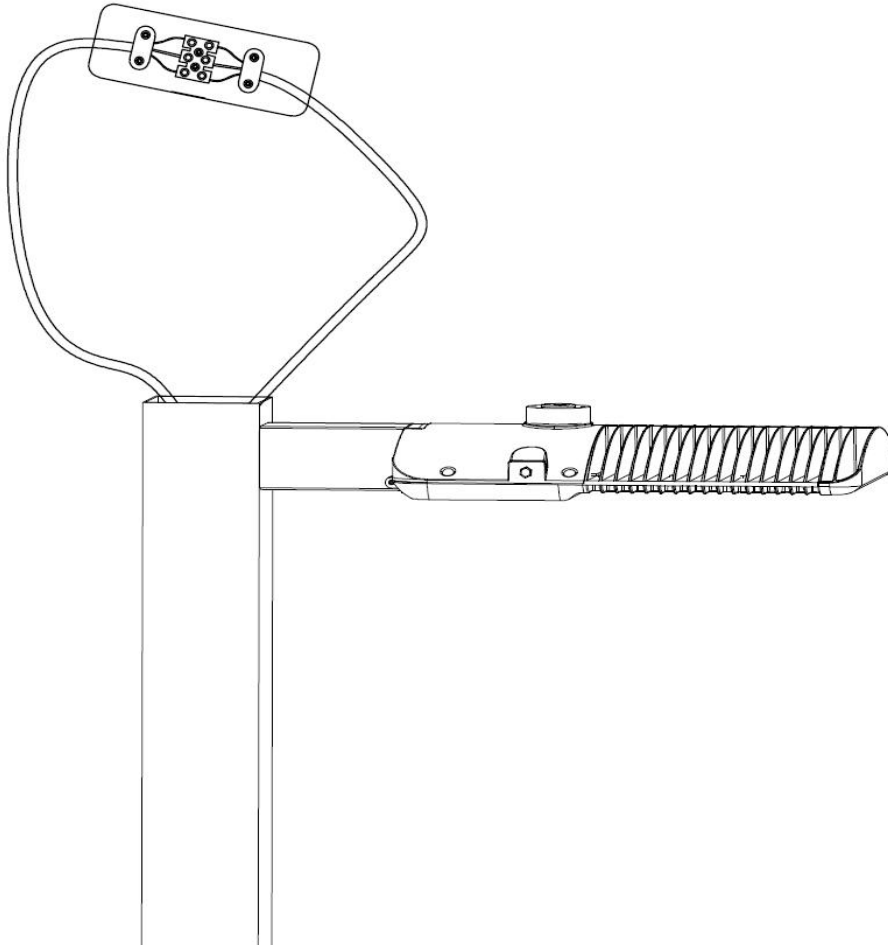

**Step 5** The installed Parking Lot Light will be as shown in the picture

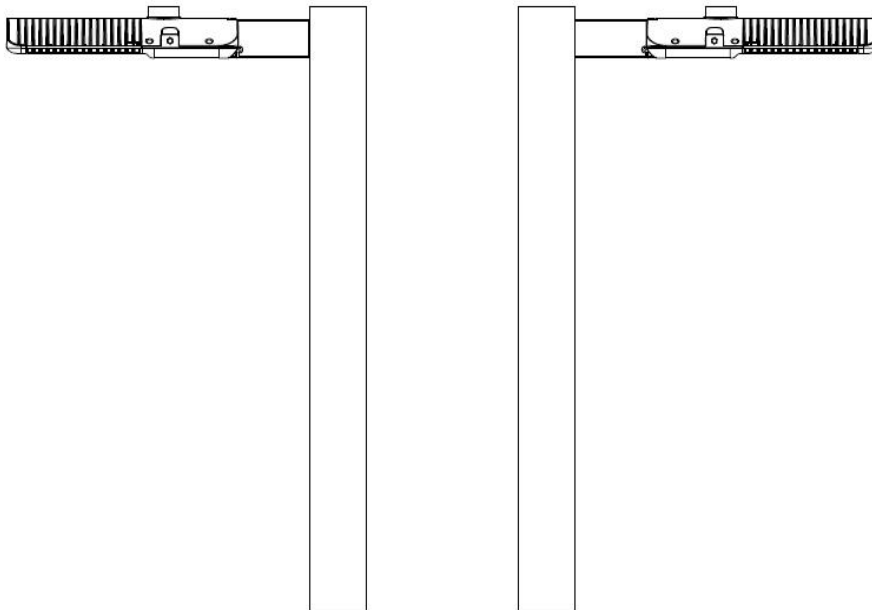

Installation Instruction for AOK IT LED Parking Lot Light

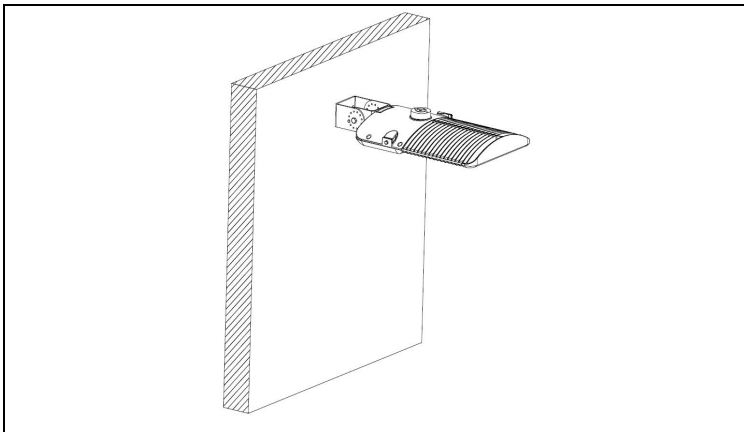

Please read the installation manual carefully before installation and keep the manual for future use.



**Warning**

1. Electrician must have related certificates, knowledge and working experience. The work must be assigned to each electrician based on their position and responsibility.
2. The lens of parking lot light modules are PC material, they may be scratched by any careless handling. The parking lot light must be carefully protected in installation, especially when the face of luminaire is put downward, it needs to be protected with soft cloth or other protecting materials.
3. Installation must be proceeded when the electricity is shut off, no action be taken when there is electricity connected.
4. Construction must be proceeded according to related regulations, including the tools and equipments used. For example: working voltage range, Warning sign, flashing lamp, helmet, and working clothes etc.
5. Make sure the weather is suitable for high power electricity work when proceed construction.



### Statement

1. Installation of parking lot light must be proceeded with cranes with lifting platform, warning sign and flash lamp etc.
2. Installation and maintenance of Parking Lot Light must be proceeded when the electricity is off.
3. Maintenance must be proceeded with professional staff.

### Installation degree adjustment for Parking Lot Light with Wall mounting bracket

Loose and take out the M5 screws on the wall mounting bracket, adjust the bracket to desired degree, put the screws back, fasten them as below picture shown.

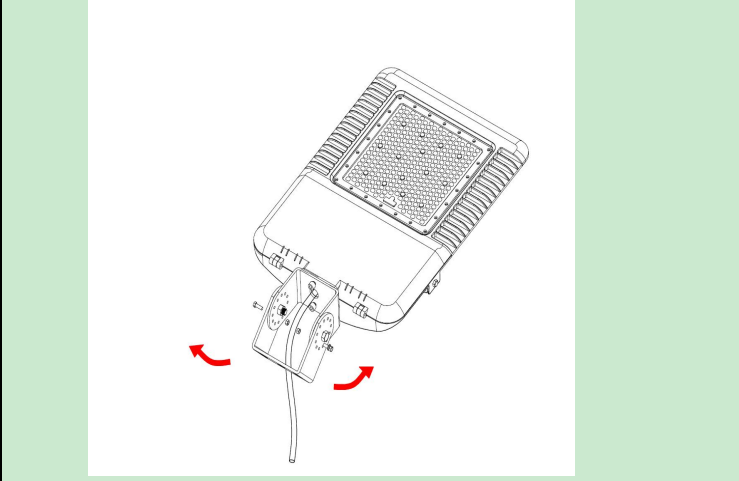

### Preparation for installation of Parking Lot Light

**Step 1:** Open the package, remove the packing materials and take out the LED Lamp

**Step 2:** Fix two setscrews on the wall according to the hole position on the bracket, make the holes on the bracket go through the setscrews, put nuts on the setscrews and fasten them. As below picture

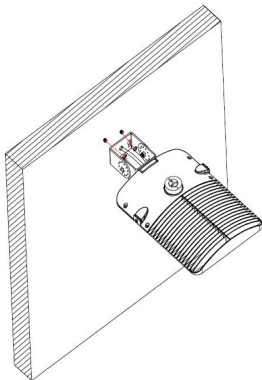

**Step 3**

Wiring, connect the L,N,GND wires on the lamp to the L,N,GND cables on the poles accordingly  
(Remark: US stanadrd Black: L, White: N, Green: GND; Eur Standard: Brown:L, Blue:N, Yellow Green: GND)

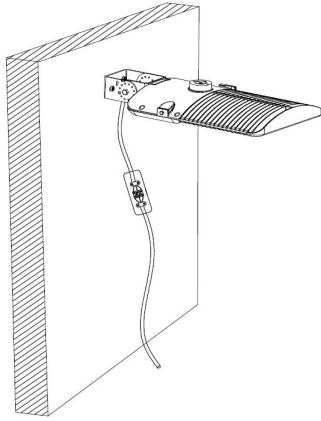

**Step 4** The installed Parking Lot Light will be as shown in the picture

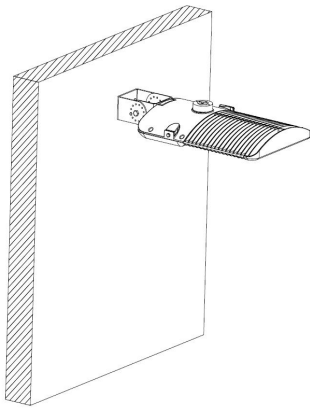

Installation Instruction for AOK iT LED Parking Lot Light

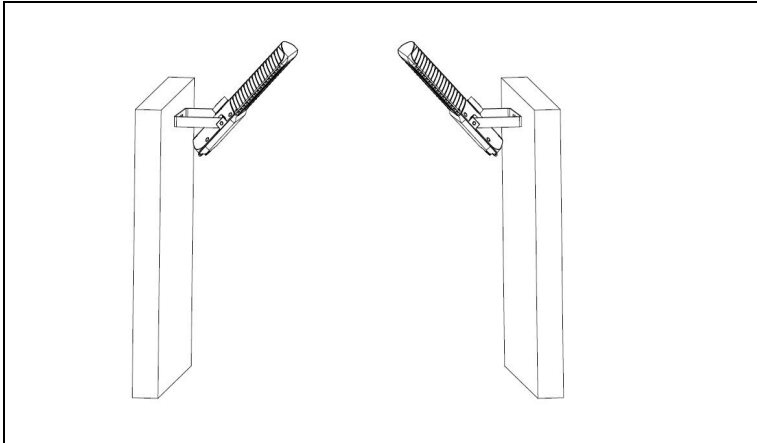

Please read the installation manual carefully before installation and keep the manual for future use.



**Warning**

1. Electrician must have related certificates, knowledge and working experience. The work must be assigned to each electrician based on their position and responsibility.
2. The lens of parking lot light modules are PC material, they may be scratched by any careless handling. The parking lot light must be carefully protected in installation, especially when the face of luminaire is put downward, it needs to be protected with soft cloth or other protecting materials.
3. Installation must be proceeded when the electricity is shut off, no action be taken when there is electricity connected.
4. Construction must be proceeded according to related regulations, including the tools and equipments used. For example: working voltage range, Warning sign, flashing lamp, helmet, and working clothes etc.
5. Make sure the weather is suitable for high power electricity work when proceed construction.



## Statement

1. Installation of parking lot light must be proceeded with cranes with lifting platform, warning sign and flash lamp etc.
2. Installation and maintenance of Parking Lot Light must be proceeded when the electricity is off.
3. Maintenance must be proceeded with professional staff.

## Installation degree adjustment for Parking Lot Light with U shape

Loose and take out the M5 screws on the U shape bracket, adjust the bracket to desired degree, fasten and fix the screws again as below picture shown.

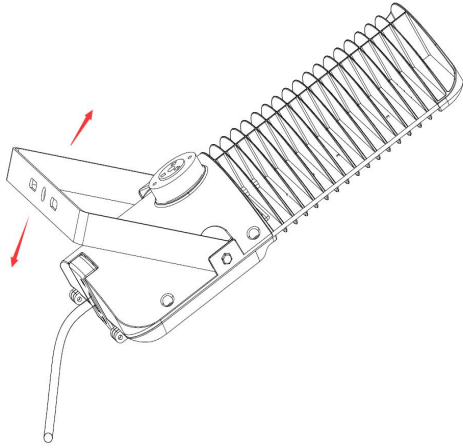

## Preparation for installation of Parking Lot Light

**Step 1:** Open the package, remove the packing materials and take out the LED Lamp

**Step 2:** Fix two setscrews on the wall according to the hole position on the bracket, make the holes on U shape bracket go through the setscrews, put nuts on the setscrews and fasten them. As below picture shown

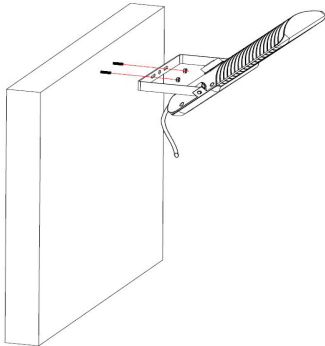



**Step 3**

Wiring, connect the L,N,GND wires on the lamp to the L,N,GND cables on the poles accordingly  
(Remark: US stanadrd Black: L, White: N, Green: GND; Eur Standard: Brown:L, Blue:N, Yellow Green: GND)

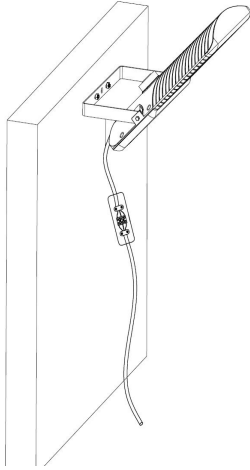

**Step 4** The installed Parking Lot Light will be as shown in the picture

